



Software Tools: Congestion Management

Tom Qi Zhang, PhD

CompuSharp Inc.

(408) 910-3698 Email: zhangqi@ieee.org

October 16, 2004

IEEE PES-SF Workshop on Congestion Management



San José State
UNIVERSITY



COMPUSHARP



Contents

- Congestion Management (CM)
- Power system modeling and computer simulation
- Review of CM software tools
- CM techniques





Why Congestion Management?

The U.S. **transmission grid** will be expanded by **3.5%** over the next 10 years compared with a **33%** announced expansion in **generation resources** over the next five years. [Source: NERC]





Grid Not Keep Pace With Generation

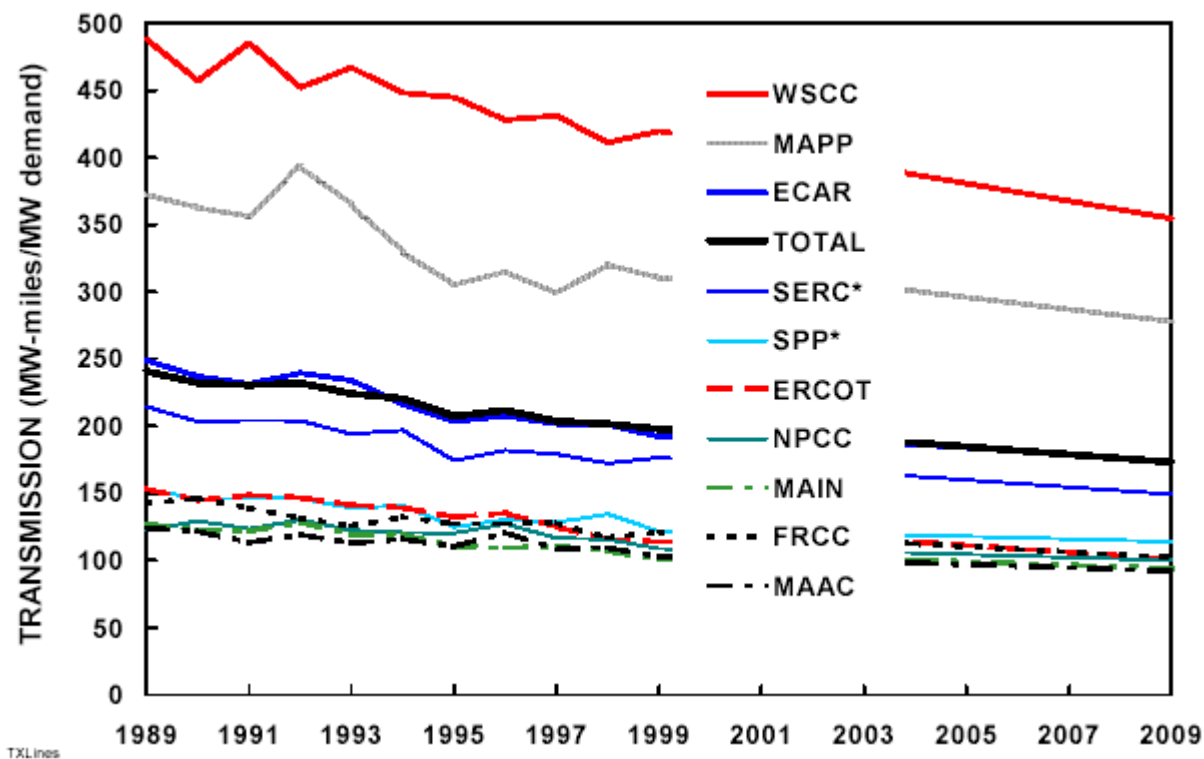

Transmission congestion is aggravated by the fact that **transmission capacity relative to peak load has declined** in every region of the U.S. **for the past ten years** and is expected to continue declining for the next ten years.



Power System Modeling

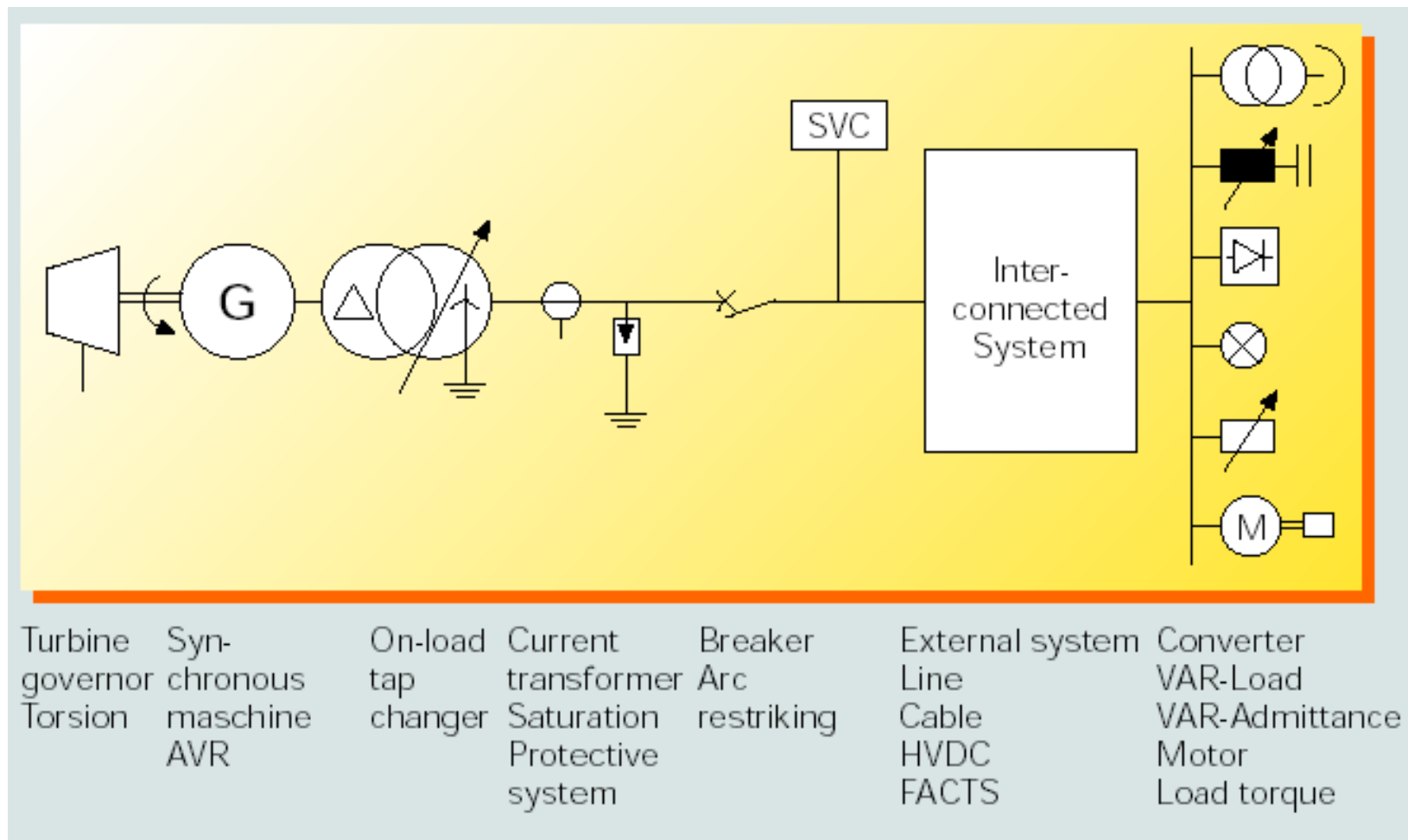



Power System Computer Simulation

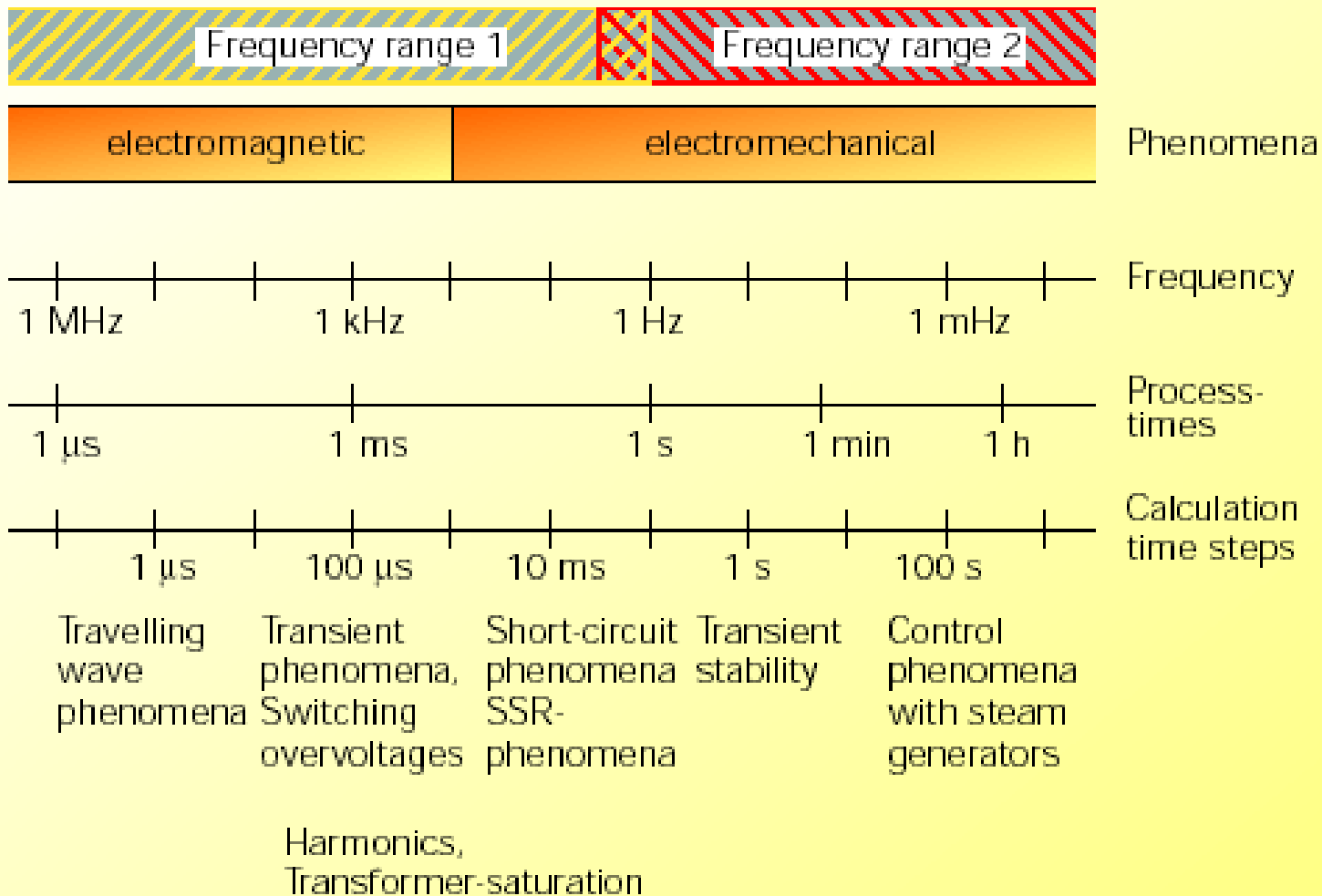



Power System Software

- **PSAPAC**



- **PSS/E**



- **NETOMAC**

SIEMENS

- **Other Software** : DIgSILENT, BPA, SIMPOW, EUROSTAG, EMTP/ATP, EMTDC, MATLAB toolbox

- **Power electronics simulation software**: PSPICE, SABER



Congestion Management Software

- **PROMOD IV**



SIEMENS

- **LMPSIM** (Location Marginal Pricing Simulator)



- **PowerWorld Simulator**



- **UPLAN-NPM**



- **PJM e-FTR Tool**





PROMOD IV



SIEMENS

With over 80 clients worldwide, the PROMOD IV integrates **energy market simulation** and **transmission analysis** to provide information for:

- Market Price Forecasting
- Unit Profitability Assessment
- Transmission Congestion Management
- System Cost Control





SIEMENS

- Detailed unit generation and revenue forecasts
- Unit bidding strategy development
- Regional and bus level location market price forecasts
- Transmission congestion and expansion studies
- FTR bidding and value determination
- Emission allowance utilization and price impacts
- Maintenance planning and optimization
- Reliability assessment
- Market price volatility assessment

<http://www.newenergyassoc.com/products/promod/>



LMP and Congestion

**Exhibit 5: Locational Marginal Prices and Congestion
January 1, 2000 to October 31, 2000**

Region	Average Price	Maximum Price (in \$/MWh)	Minimum Price	# Hours Congested	Frequency of Congestion
California ISO					
ZP-26	80.54	750.00	-329.00	927	14.1%
SP-15	84.40	750.00	-329.00		
PJM					
Western Hub	25.16	483.30	0.00	2024	27.7%
PPL(CentralPA)	25.23	483.32	-5.27		
NewYork ISO					
West(Buffalo)	32.08	169.13	0.01	3606	49.0%
NYC	46.76	1012.05	0.01		

Source: Beacon Energy, PJM, NY-ISO, CAISO

**Exhibit 6: Cost of Congestion From
January 1, 2000 to October 31, 2000**

Region	LMP Differences (\$/MWh)			YTD Sum
	Average	Max	Min	
California ISO (SP-15 minus ZP26)	156	775	-58.75	38,971.00
PJM (PPL minus Western Hub)	0.24	135.61	-43.76	483.11
NewYork ISO (NYC minus West)	19.09	915.29	-45.52	68,825.00

Source: Beacon Energy, PJM, NY-ISO, CAISO



LMP 101 **Analogy**

<http://www.pjm.com/services/training/train-materials.html>

- LMP is analogous to a taxi ride for MWs!
 - Heavy traffic = Higher fare

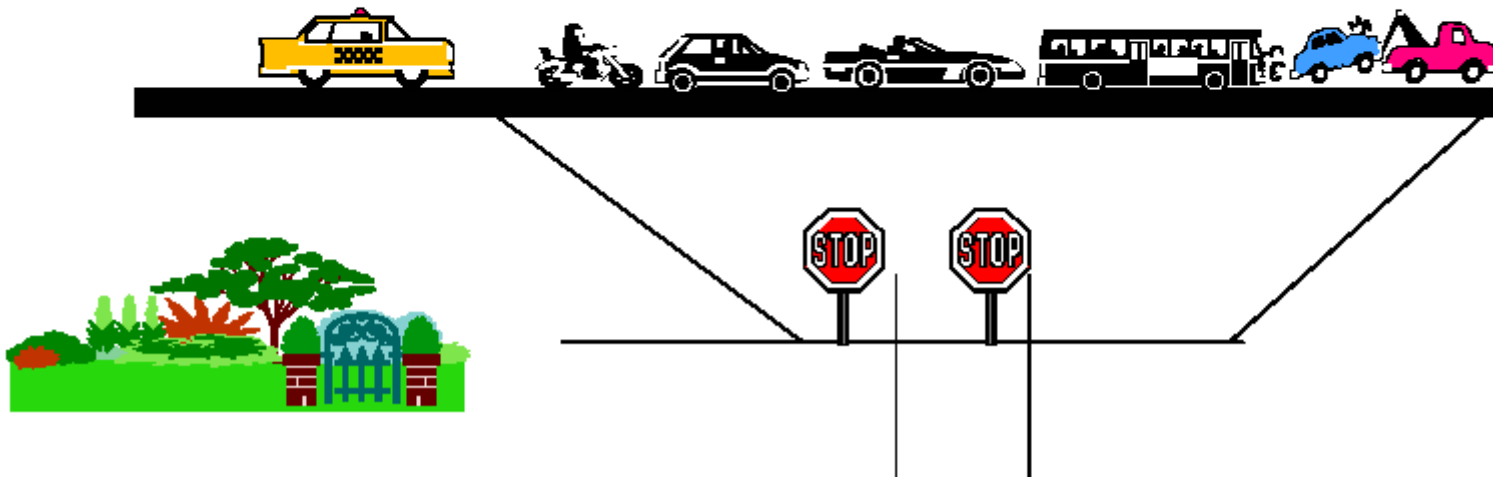

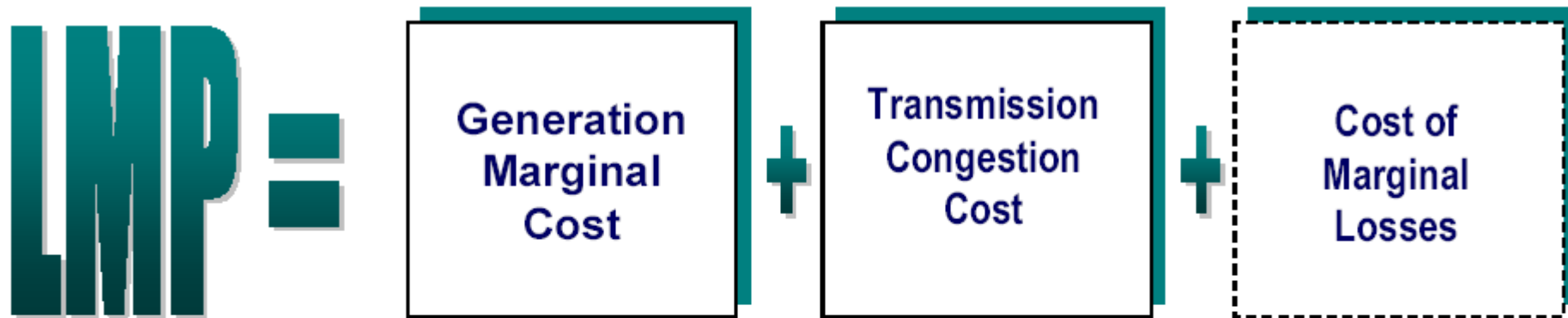

Cost to serve the next MW of load at a specific location, using the lowest production cost of all available generation, while observing all transmission limits



LMP 101

Highest Cost Generator Sets Price

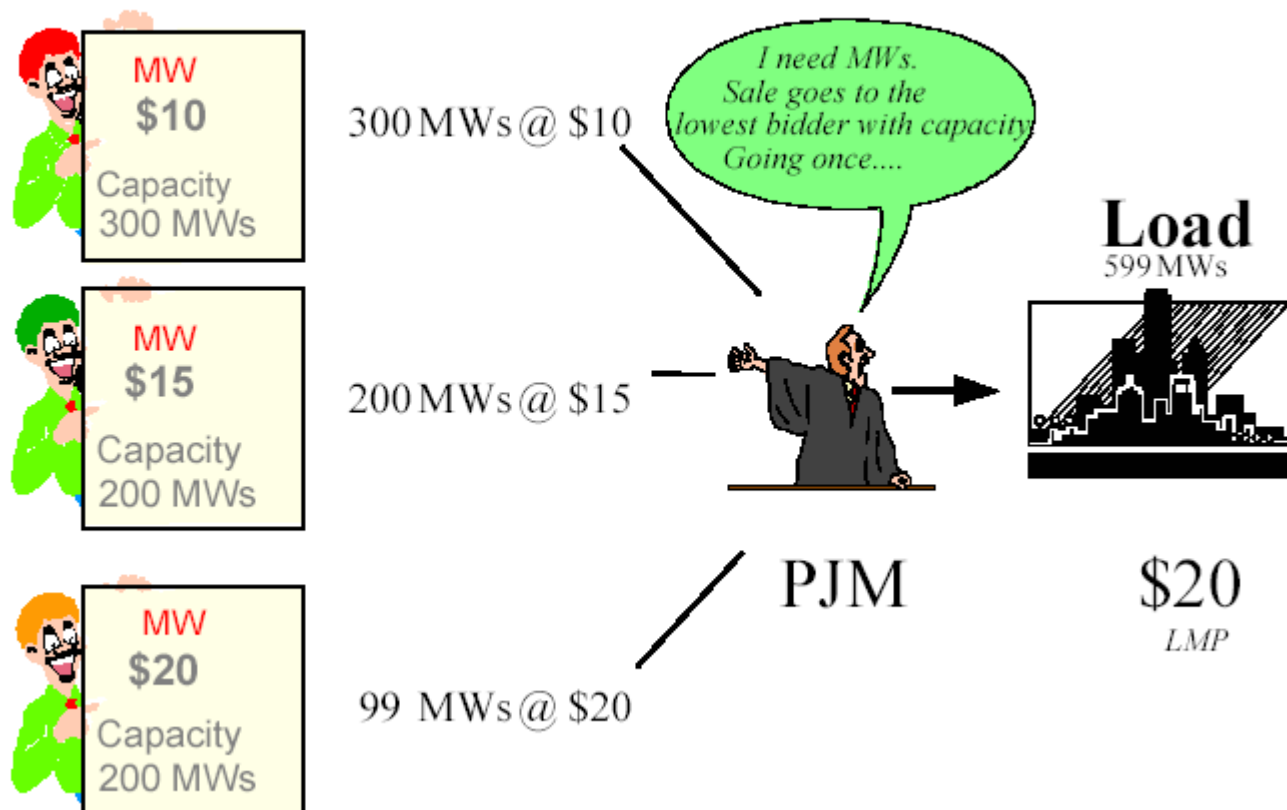



PROMOD IV



Methodology

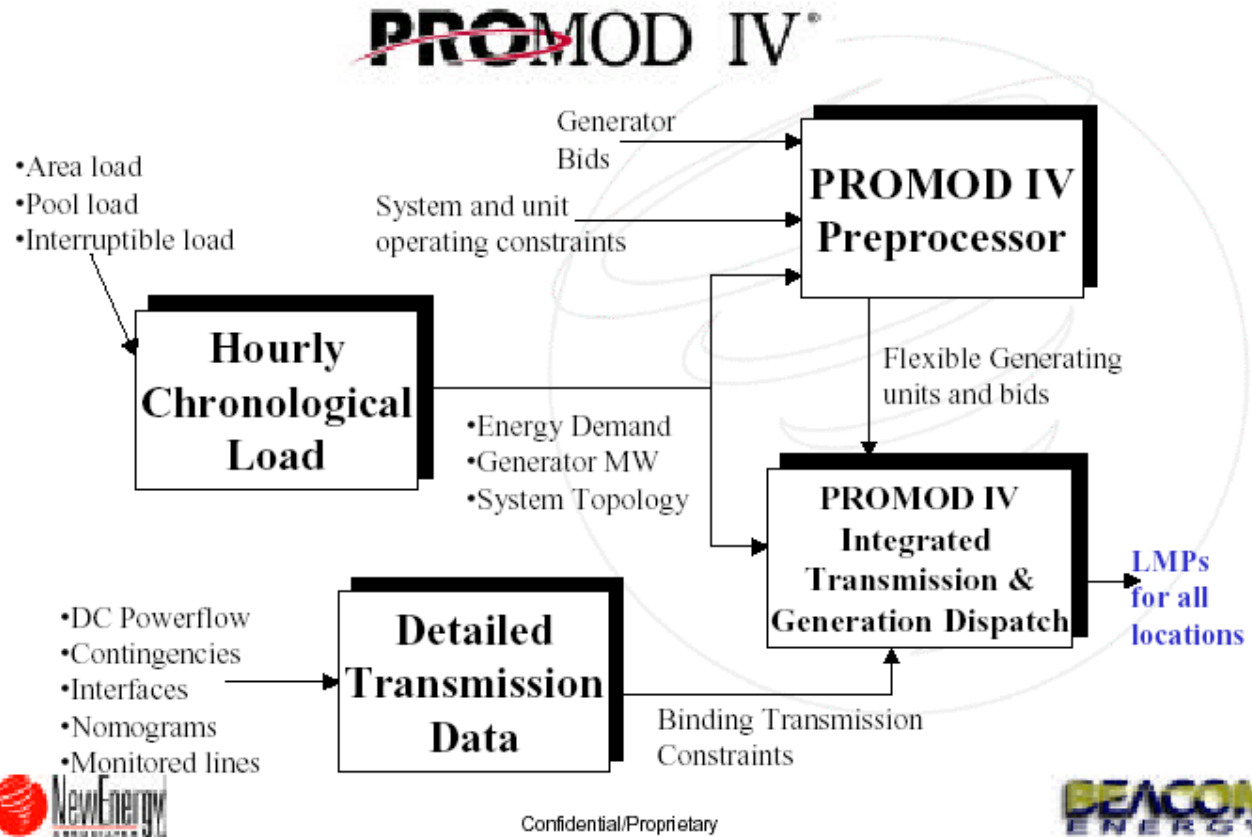



PROMOD IV Algorithm

- Forecast the hourly Locational Marginal Price **on bus level**
- Integrate the generation and transmission simulation model
- To provide a robust solution regarding the generation system, PROMOD IV applies a **Monte Carlo algorithm** that considers unit availability as the random variable. This methodology is attractive because it allows evaluation of the system under a variety of unit-forced outage scenarios.
- Integrates a **DC power-flow** with the generation system.
- PROMOD IV has to rely on **user input** forecasts for load, unit dispatch price characteristics or unit bids.



PROMOD IV **Algorithm**

- The transmission analysis module (TAM) of PROMOD IV performs a **chronological hourly dispatch** of the generation system while adhering to the detailed constraints and characteristics of the transmission grid under both normal and contingency conditions.
- PROMOD IV uses a **single power-flow**, usually from the peak hour of the summer, for its forecast and relies upon user forecasts for changing transmission topology.



PJM: Locational Marginal Pricing (LMP) Model

Methodology

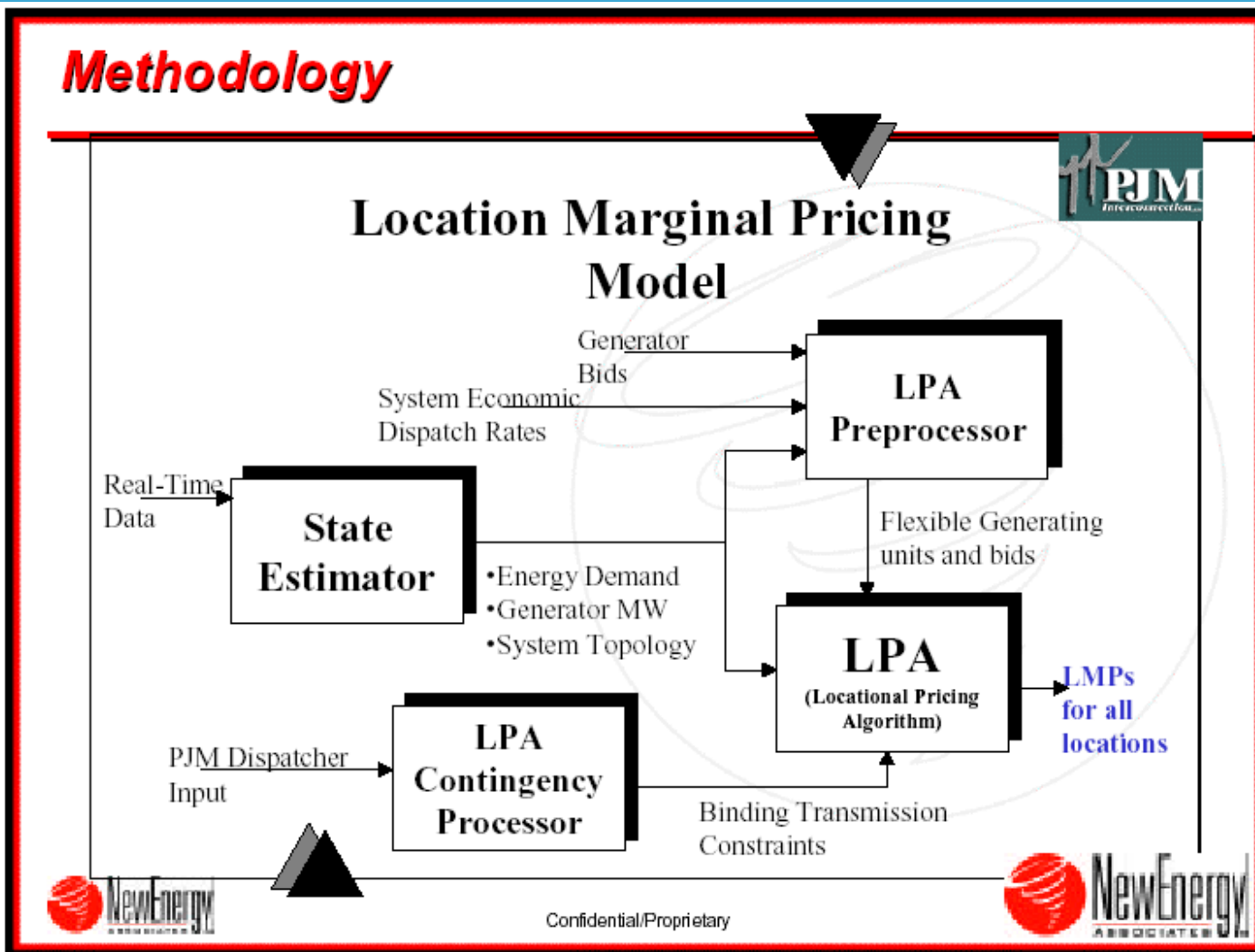



PJM: Locational Marginal Pricing (LMP) Model

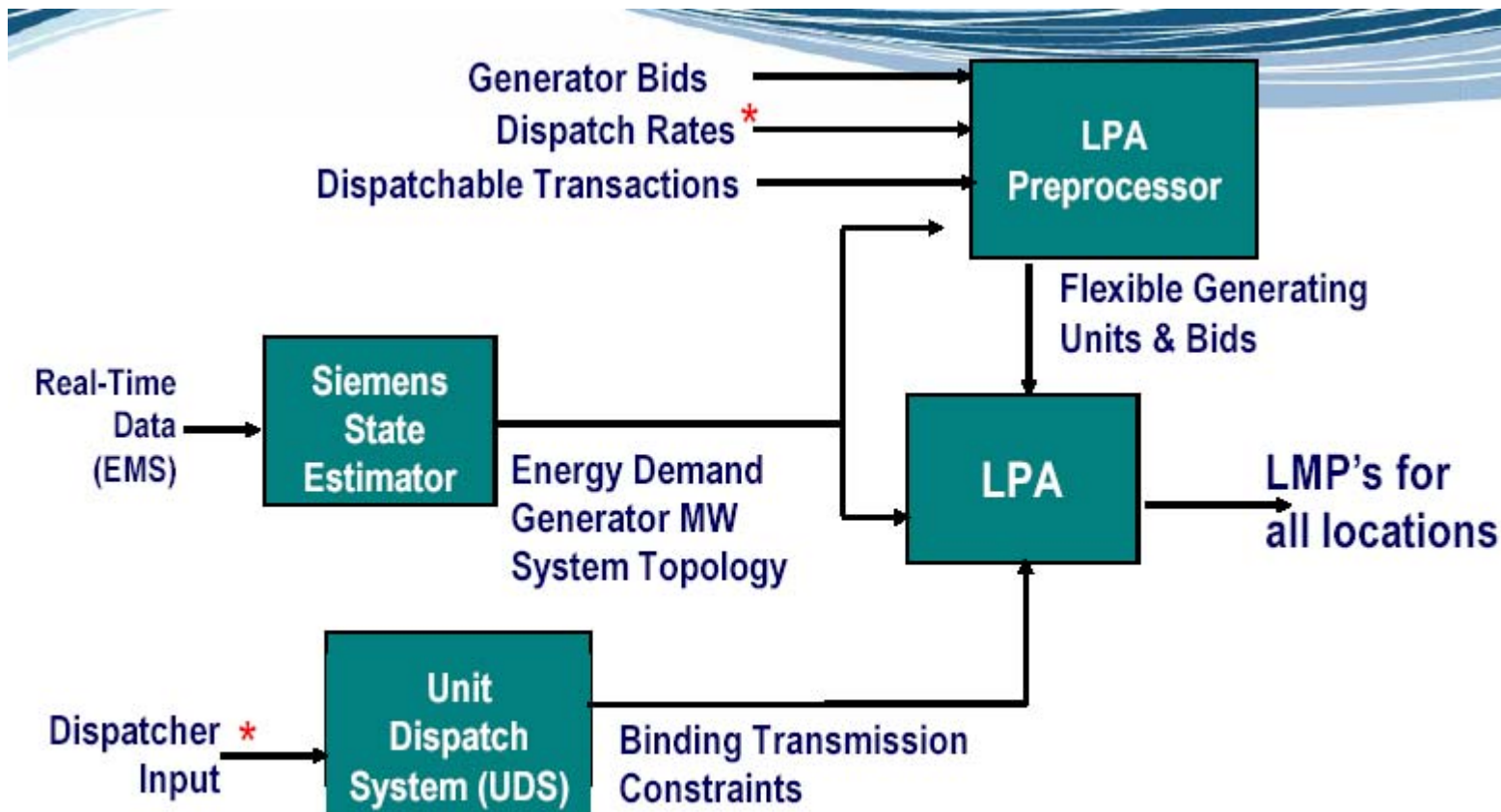

* Manual Dispatcher Input

LPA = Locational Pricing Algorithm



PJM: LMP Execution Process

- ❶ Determine current system conditions
 - ✱ energy demand
 - ✱ generator MW values
 - ✱ system topology
- ❷ Process generator bids & dispatch rates to determine flexible generators
- ❸ Collect current system constraint data
- ❹ Execute Locational Price Algorithm



How to calculate LMP?

LMP
Price



$$\lambda_n = \lambda_s + (DF_n - 1) * \lambda_s + \sum \alpha_{nk} * \mu_k$$

Cost of losses incurred for the
next MW of load at the node



System Marginal Cost at
Reference Node



Cost of transmission limits
incurred for the next MW of
load at the node





PowerWorld Simulator

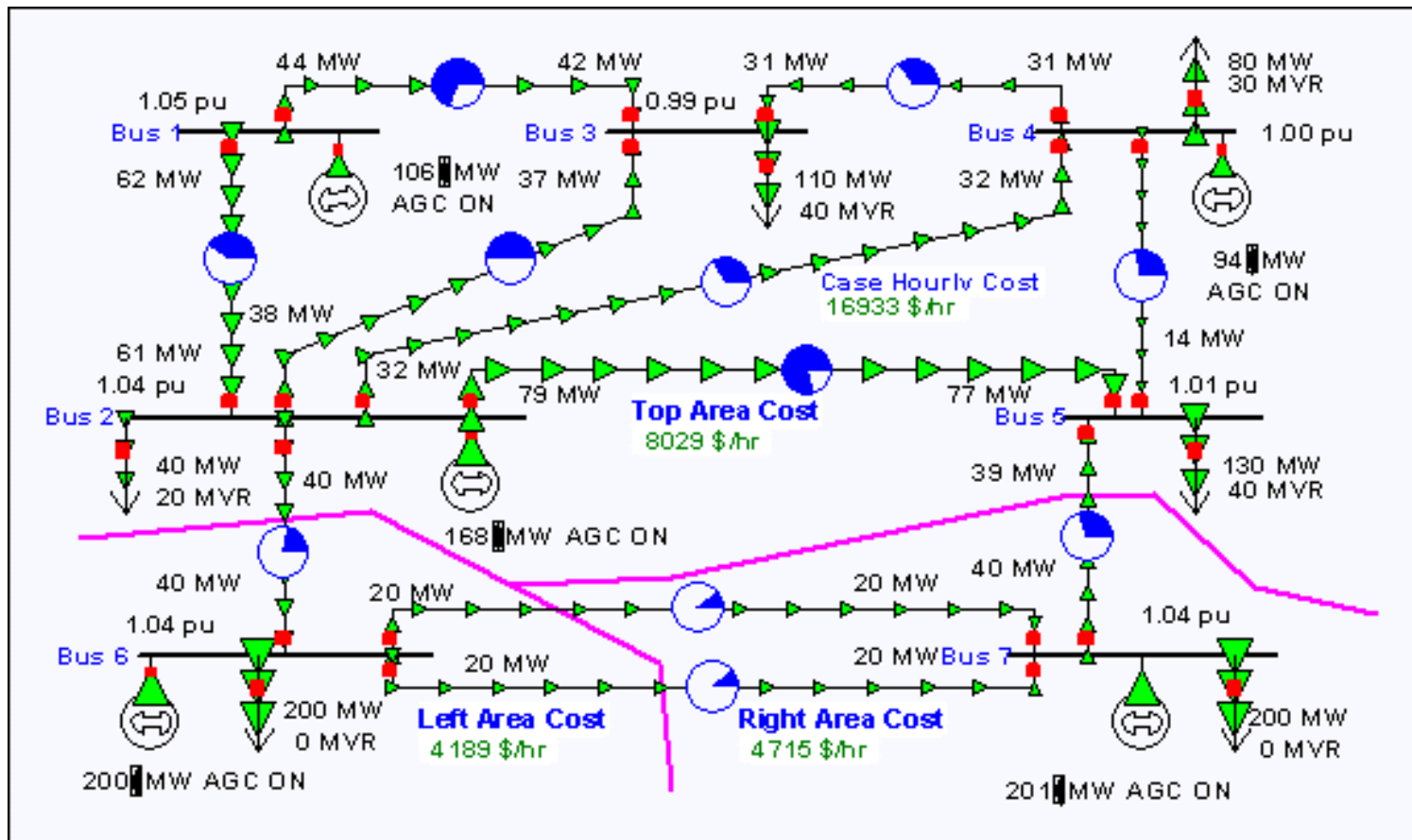

<http://www.powerworld.com>



Power Flow Equation

$$\begin{cases} P_{Gi} - P_{Di} = \sum_{k \in i} |V_i| |V_k| [g_{ik} \cos(\theta_i - \theta_k) + b_{ik} \sin(\theta_i - \theta_k)] \\ Q_{Gi} - P_{Di} = \sum_{k \in i} |V_i| |V_k| [g_{ik} \sin(\theta_i - \theta_k) - b_{ik} \cos(\theta_i - \theta_k)] \end{cases}$$

(1) Nodal power balance equations

$$\begin{bmatrix} I_1 \\ \cdot \\ I_n \end{bmatrix} = \begin{bmatrix} y_{1,1} & \cdot & y_{1,n} \\ \cdot & \cdot & \cdot \\ y_{n,1} & \cdot & y_{n,n} \end{bmatrix} \times \begin{bmatrix} V_1 e^{j\theta_1} \\ \cdot \\ V_n e^{j\theta_n} \end{bmatrix}$$

(2) Nodal current balance equations



Optimum Power Flow (OPF)

Objective Function

Currently two objective functions are available in Simulator OPF:

- **Minimum Cost**
- **Minimum Control Change**

Minimum Cost attempts to **minimize the sum of the total generation costs** in specified areas or super areas.

Minimum Control Change attempts to **minimize the change in the generation** in the specified areas or super areas.





Linearized DC Load Flow V.S. AC Full Load Flow

- Tradeoff computational speed versus the accuracy of the result
- DC load flow is commonly used in power market modeling
 - Kirchhoff's Law are respected i.e. power flows balance, and loop flow is modeled
 - Computational speed and scalability – it can be solved with a linear program
 - The OPF can be fully integrated into the economic dispatch and leads directly to calculation of location marginal prices
 - The data requirements are significantly less than for a full AC OPF



Lossless DC Load Flow Model

Assumption:

- Each transmission line is represented by its susceptance b_{ij} .
- The bus voltage angular differences are assumed to be small and the voltage magnitudes approximately 1 p.u. (per unit)
- Impedance = $r + j x$
- Inverse of impedance = $G + j B$
 - $G = r / (r^2 + x^2) \approx 0$
 - $B = -x / (r^2 + x^2) \approx -1 / x$

These assumptions hold for high voltage (low loss) systems operating with voltage magnitudes close to 1.00



Real Power Flow

The real power flow on each line is given by

$$P_{ij} = B_{ij} (\delta_i - \delta_j)$$

where δ_i and δ_j represent the voltage angles at buses i and j , respectively.



Constraint Equation for OPF

The constraint equations for OPF are:

$\mathbf{f}_{(k,l)} = \mathbf{Y}_{(k,l)} (\theta_k - \theta_l)$	Power flow definition (loop flow equation)
$\mathbf{f}_{(k,l)}^{\min} \leq \mathbf{f}_{(k,l)} \leq \mathbf{f}_{(k,l)}^{\max}$	Flows are within bounds (thermal limits)
$P_i = g_i - L_i$	Net injection equals generation – load
$P_i = \sum_l (\mathbf{f}_{(i,l)}) - \sum_k (\mathbf{f}_{(k,i)})$	Net injection equals exports – imports
$g_i \leq g_i^{\max}$	Generation within bounds
P_i free	
θ_k free, $\theta_0 = 0$	Phase angle = 0 at swing bus



UPLAN-NPM



Dispatch Based Unit Commitment and Integrated Market Simulation

Objectives

- Dispatch Based (LMP) unit commitment
- Energy and Ancillary Service Procurements
- Congestion Management
- LMP Pricing
 - Congestion cost
 - (Marginal) Transmission Losses

Unique Features

- Rolling Forward looking Unit Commitment
- Integrated Energy, A/S, Security Constrained Load flow based Unit Commitment
- Nash equilibrium Prices for Energy, A/S and Capacity
- Security Constrained Economic Dispatch, optimized re-dispatch (DC or AC OPF) for Congestion Management

Integrated Market Simulation SCUC and SCED

Loads and Resources

- Generator Type, Location, Operating status
- Generator operating characteristics
- Financial characteristics
- Energy and Ancillary Service Capability
- Generator Costs, Bids, Caps, Losses
- Hourly Loads At Each Bus
- Demand Bids and Caps

Transmission Resource

- Full Network Model
 - Line & Bus Characteristics
 - ratings
 - Contingencies
 - Flowgate
 - Impedance (Resistance, reactance, Capacitance etc.)
 - Phase Shifter, Location, Mileage etc

Model Output

- Generator Costs, Revenue, Uplift, Net Income, Fuel Consumption
- LMP, Marginal & average losses
- Energy & ancillary Service Prices and Revenue
- Capacity Prices
- Congestion Cost & Congestion Revenue Rights, Shadow Price
- Load Flow, Branch Overload, GSF
- Zonal flows, Loads, Generation,
- Zonal Prices, Imports, Exports
- Customized Reports



UPLAN Features



- Day-Ahead Market Model
- Real-time Dispatch Model
- Provides locational marginal (LMP) prices
- Fulfills all the modeling requirements of FERC Standard Market Design (SMD) order
- AC/DC optimal power flow (OPF)



UPLAN



Comparison of Prices With and Without N-1 Contingency

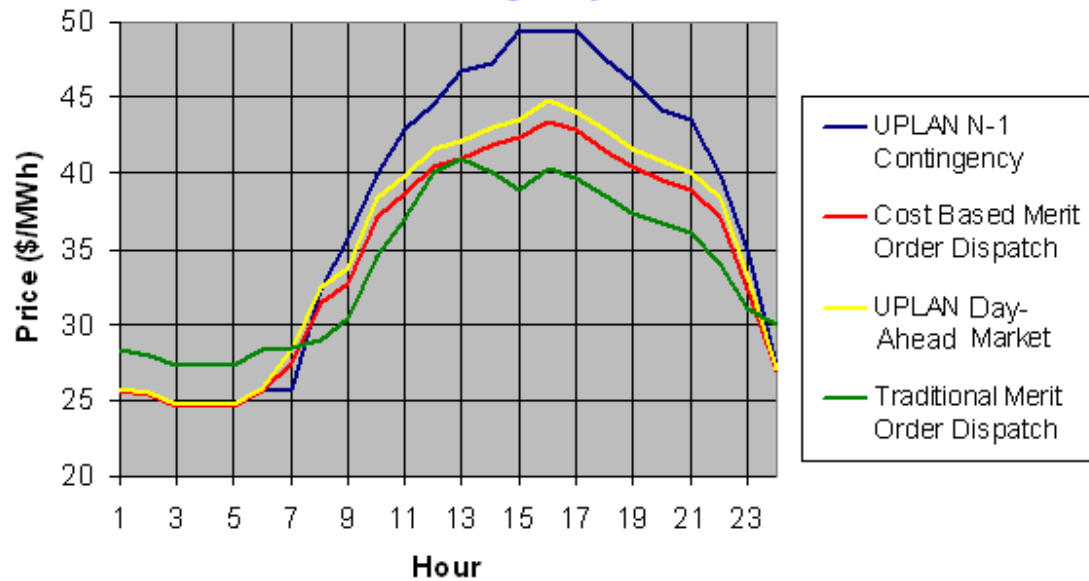

UPLAN Day-Ahead Market Simulation Energy & Ancillary Service Price Forecast

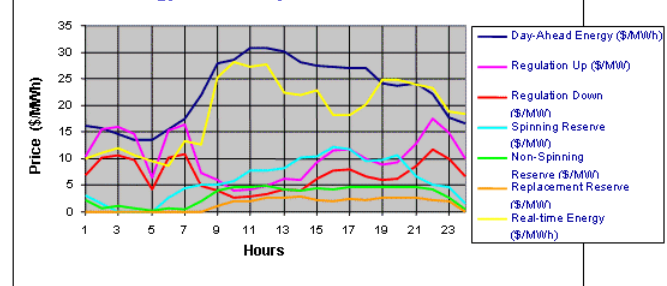



PJM eFTR Tool



eFTR is an internet application that allows PJM Market Participants to participate in PJM's FTR auction and secondary market,... and ARR auction and trading. <https://esuite.pjm.com/mui/index.htm>

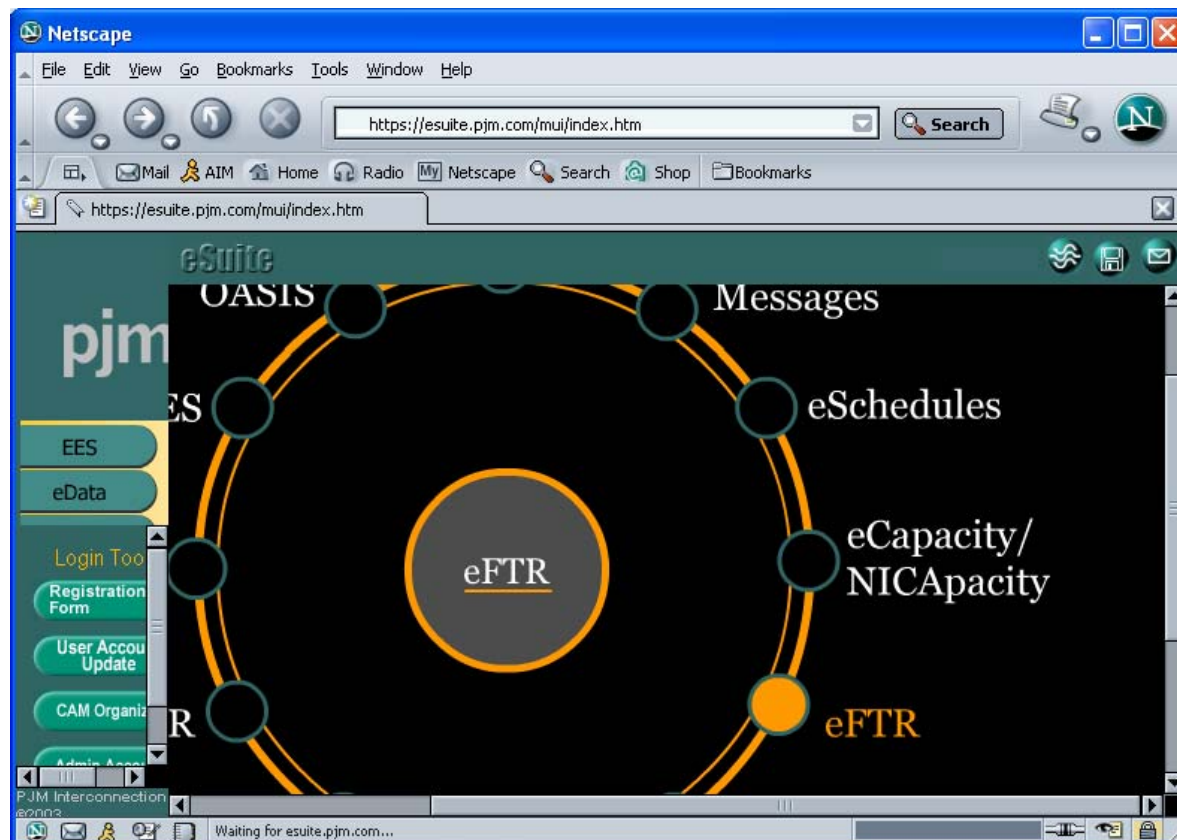



What are FTRs?

Financial Transmission Rights are ...

financial instruments that entitle the holder to a stream of revenues (or charges) based on the hourly Day Ahead energy price differences across the path

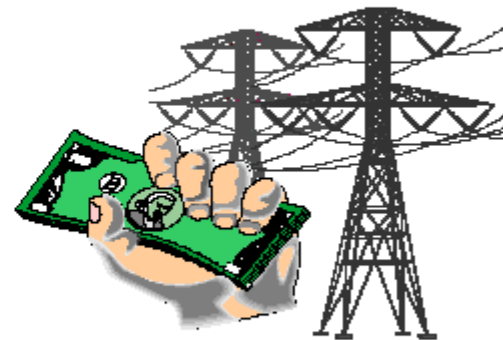



Why Do We Need FTRs?



- **Challenge:**
 - **LMP exposes PJM Market Participants to price uncertainty for congestion cost charges**
 - **During constrained conditions, PJM Market collects more from loads than it pays generators**
- **Solution:**
 - **Provides ability to have price certainty**
 - **FTRs provide hedging mechanism that can be traded separately from transmission service**



FTR Credits and Congestion Charges

**Congestion Charge =
MWh*(Day-ahead Sink LMP - Day-ahead Source LMP)**

**FTR Credit =
MW*(Day-ahead Sink LMP - Day-ahead Source LMP)**



eFTR Market User Interface

Portfolio Management

The screenshot shows a web browser window displaying the eSuite interface. The browser address bar shows the URL: <https://esuiteest.pjm.com/mui/index.htm>. The interface includes a navigation menu on the left with options like EES, eData, eSchedules, eMarket, eFTR, and FTR Main. The main content area shows the 'Portfolios' section with a dropdown menu set to 'Test' and buttons for 'Create Portfolio' and 'Delete Portfolio'. Below this, there is a table listing portfolios with columns for 'Source' and 'Sink'. The table contains one entry: AEPVPEXP (Source) and PRIDE 25 KV STONEYCR (Sink).

	Source	Sink
<input type="checkbox"/>	AEPVPEXP	PRIDE 25 KV STONEYCR



The screenshot shows a Microsoft Internet Explorer browser window displaying the PJM eSuite website. The address bar shows the URL: <https://esuite.test.pjm.com/mui/index.htm>. The browser's address bar also shows several bookmarks related to eMKT (new) and eMKT (old) for various stages and products.

The website interface includes a navigation menu with tabs for Messages, Reports, and FTR Capacity. The FTR Capacity tab is selected. Below the navigation, there are buttons for EES, eData, eSchedules, eMarket, and eFTR. The eFTR section is expanded, showing a sub-menu with FTR Main, FTR Results, FTR Quotes, FTR Trading, ARRs, and Administration.

The main content area displays the FTR Capacity report for the 03/04 Annual Auction (Annual) in Round 1 (Cleared). The report shows 10 matches. The data is presented in a table with the following columns: Source, Sink, On Peak MW, and Off Peak MW.

Source	Sink	On Peak MW	Off Peak MW
AEPVPIMP	WESTERN HUB	1700.0	1700.0
DLCO	WESTERN HUB	1700.0	1700.0
EASTERN HUB	WESTERN HUB	1700.0	1700.0
FE	WESTERN HUB	1700.0	1700.0
NYIS	WESTERN HUB	750.0	750.0
WESTERN HUB	EASTERN HUB	800.0	800.0
WESTERN HUB	NYIS	675.0	675.0
WESTERN HUB	FE	1175.0	1175.0
WESTERN HUB	DLCO	1175.0	1175.0
WESTERN HUB	AEPVPEXP	1150.0	1150.0



Accepted FTRs

Start Date : 06/02/2004 End Date : 07/31/2004

No Accepted FTRs found.

Accepted FTRs from 2004-06-02 to 2004-07-31

Pasted By	Accepted By	Source	Sink	Start	End	Clearing Price	Class	Hedge	MW	Price
-----------	-------------	--------	------	-------	-----	----------------	-------	-------	----	-------



eFTR

Post FTRs

Microsoft Internet Explorer provided by PJM Interconnection

Address: <https://esuiteest.pjm.com/mui/index.htm>

Links: PJM, PJM Life, esuite, eMKT (new) - standalone, eMKT (new) - stage, eMKT (old) Prod, eMKT (old) Trial, eMKT (old) - Tran, Collage, ServiceWise

eSuite

pjm

Post FTRs | Available FTRs | Accepted FTRs | **Confirmed FTRs** | Activity Log

Confirmed FTRs Get Report

Start Date: End Date: Change Date

No confirmed FTRs found.

Confirmed FTRs from 2004-06-02 to 2004-07-31

Source	Sink	Start	End	Clearing Price	Class	Hedge	Trade	MW	Price	Event Time (GMT)
--------	------	-------	-----	----------------	-------	-------	-------	----	-------	------------------

FTR

- FTR Main
- FTR Results
- FTR Quotes
- FTR Trading**
- ARRs
- Administration
- PJMIST
- Informing

PJM Interconnection
82002

update Trusted sites



FTR Obligation is a Benefit

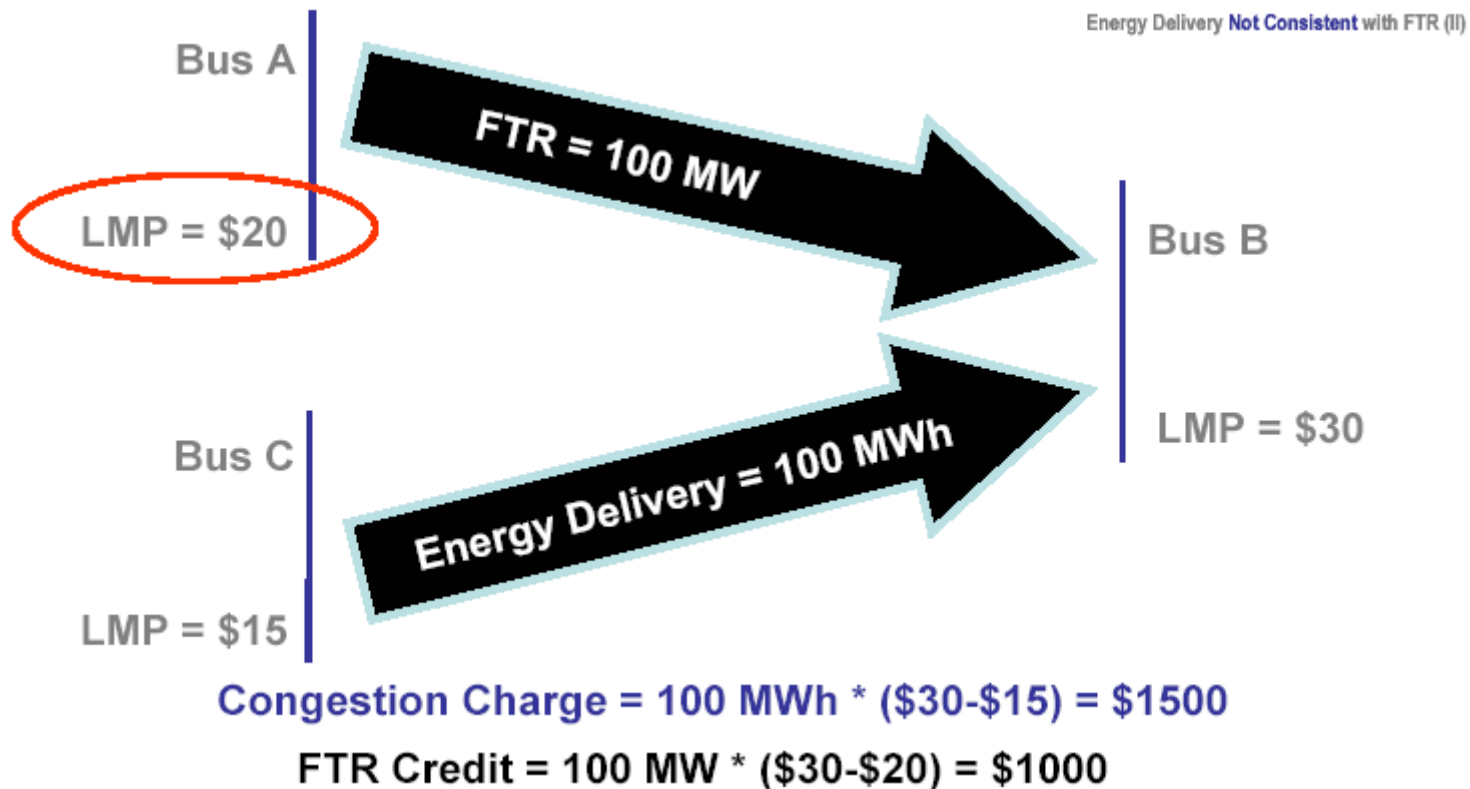



FTR Example #1 (PowerWorld Simulator)

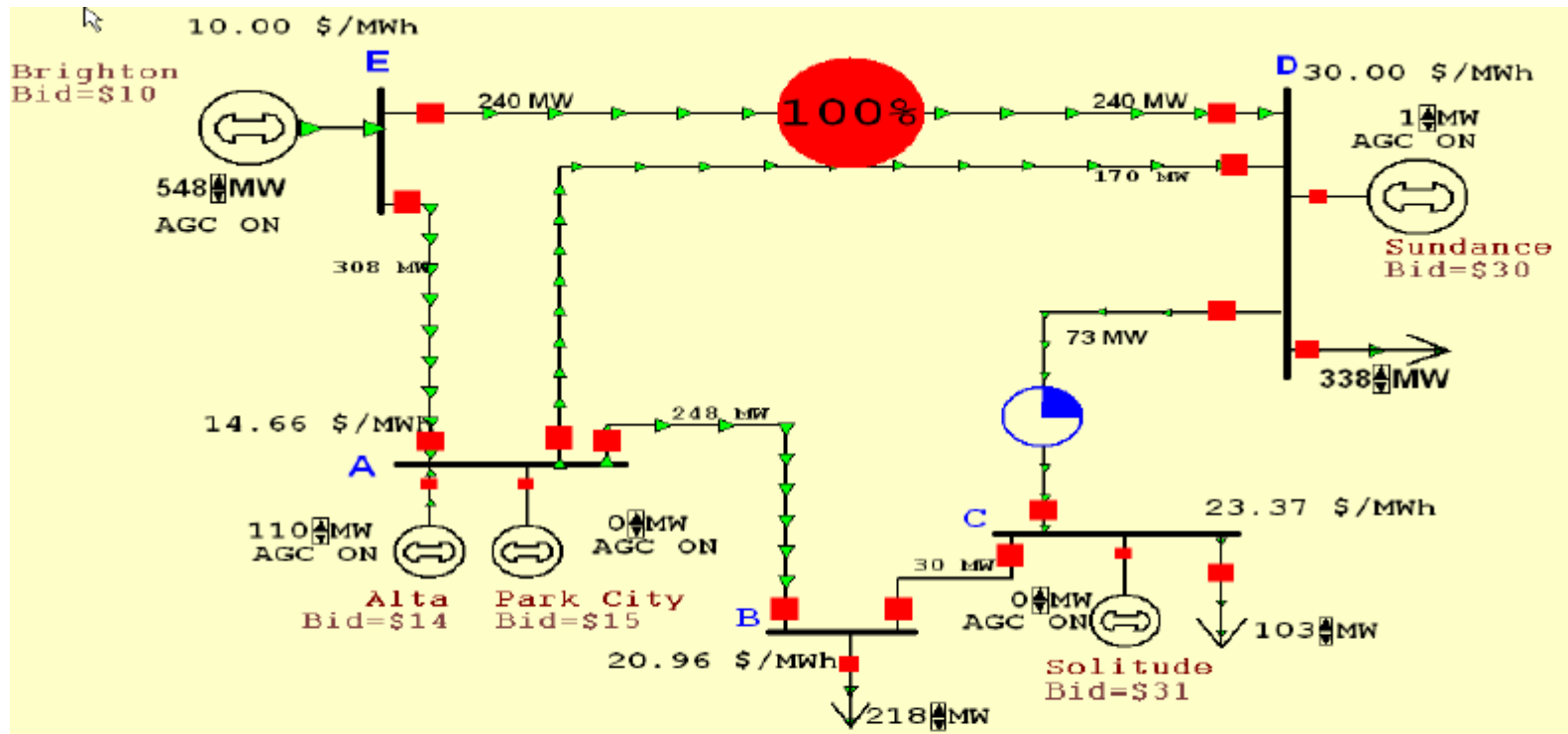

LSE D - Buying 338 MW from Brighton (bus E) through an eSchedule deal

- Source = Bus E, Sink = Bus D

- 300 MW FTR Obligation from bus E to bus D

Note: Assume DA LMP is the same as shown here.



FTR Example #1

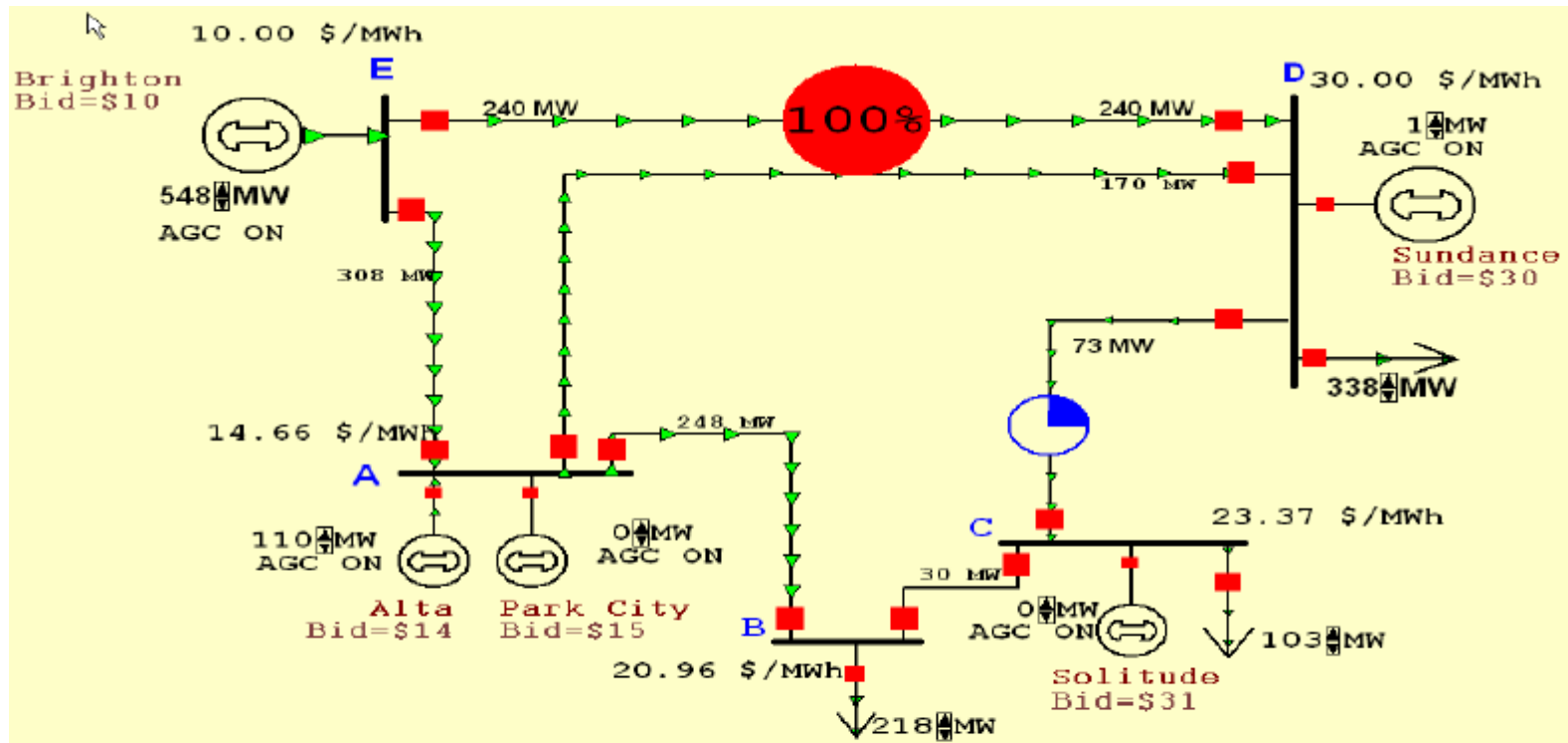

LSE D - Congestion charge (explicit) = 338 MWh x (\$30-\$10) = \$6,760

- FTR Credit = 300 MW x (\$30-\$10) = \$6,000

Net = \$760 charge



FTR Example #2

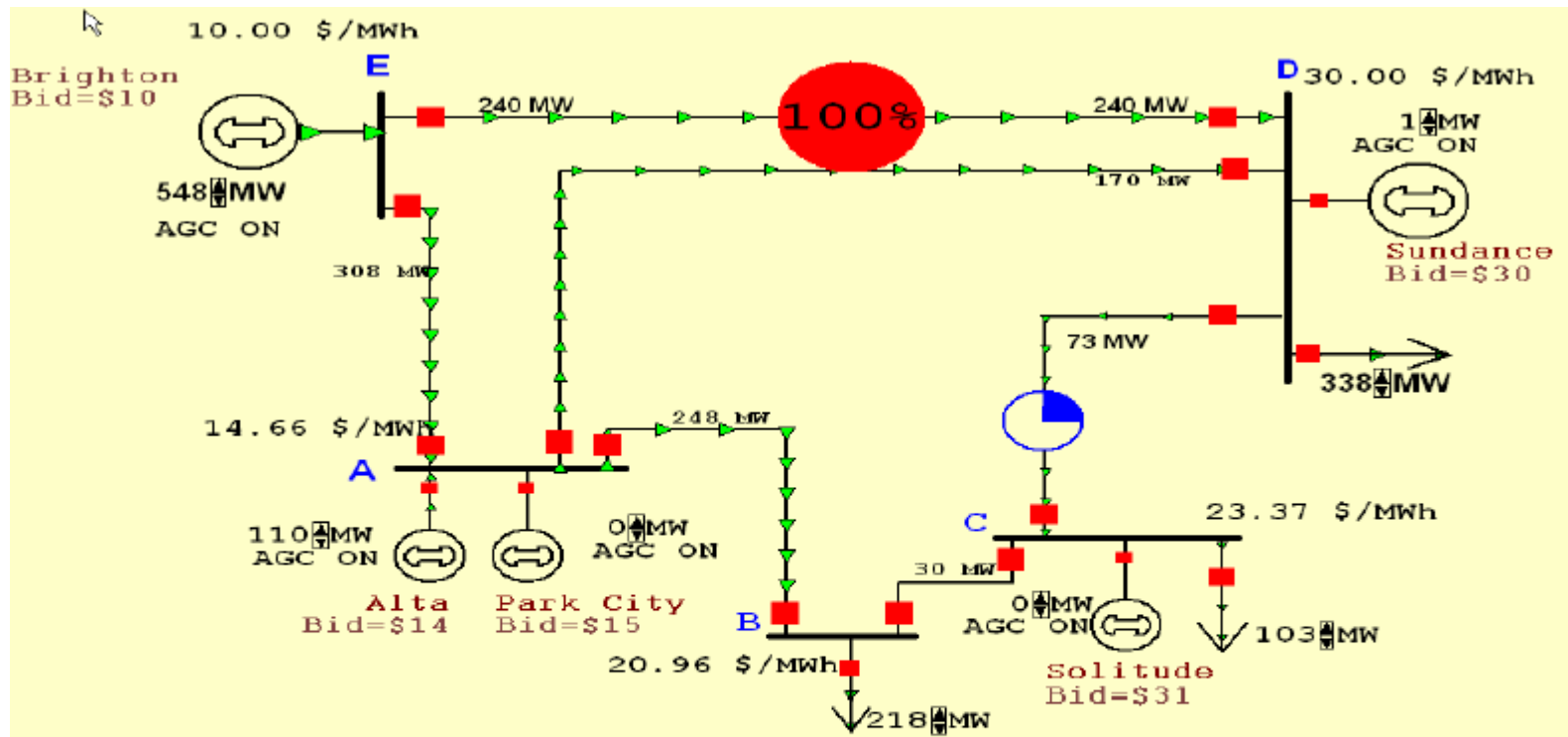

- EDC Z - Owns Alta Generation
- Serves 218 MW load at bus B
- Owns 100 MW FTR Obligation from bus D to zonal load

Note: Assume DA LMP is the same as shown here.



FTR Example #2

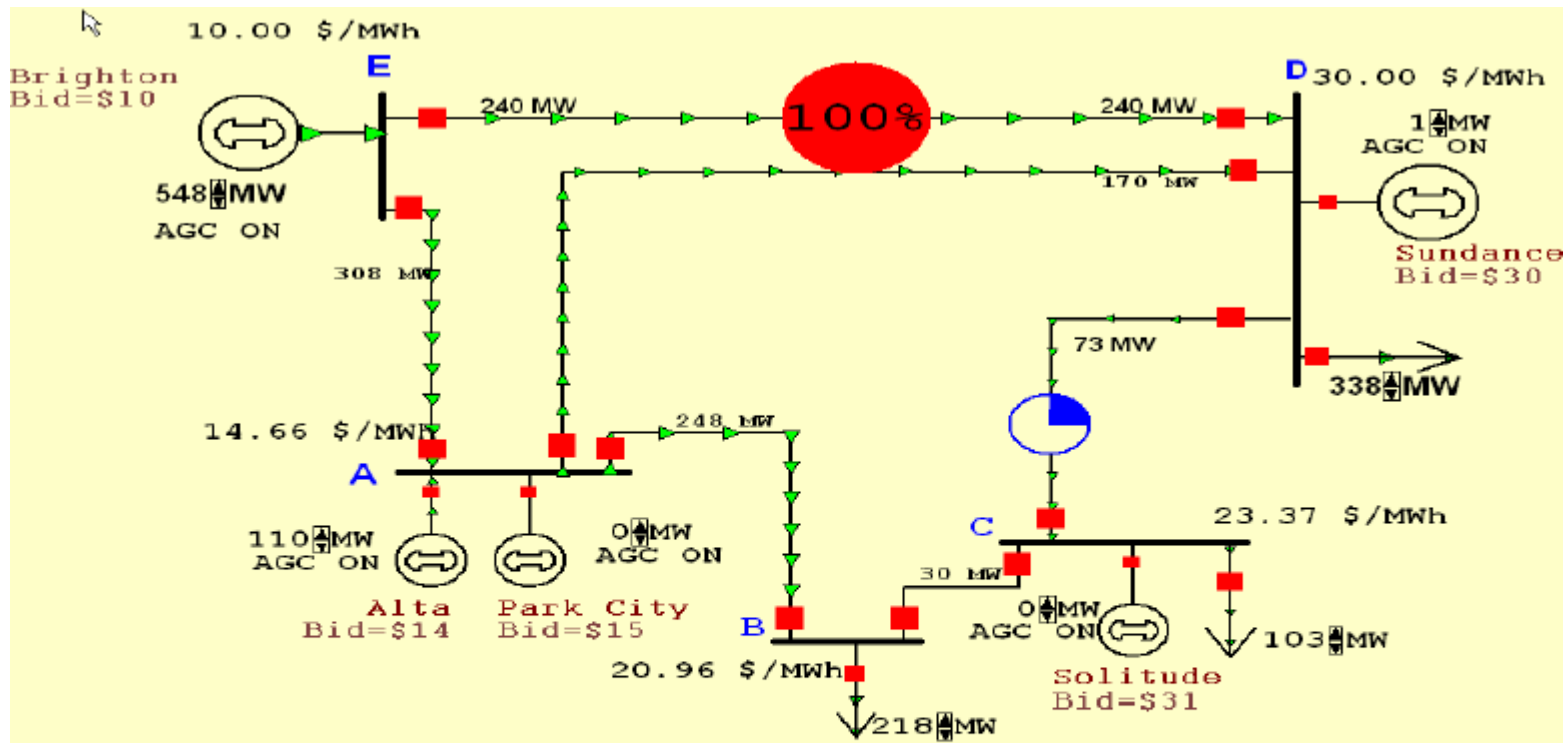

- EDC Z - Credit for Alta Generation = 110 MWh x \$14.66 = \$1612.6
 - Charge for load at bus B = 218 MWh x \$20.96 = \$4569.28
 - FTR from bus D to zone = 100 MW x (\$25.97-\$30) = (\$403)
- Net charge = \$4569.28 + \$403 - \$1612.6 = \$3359.68

Zonal DA LMP



Congestion Management Techniques

1. Cost-free Methods

- Adjust transformer taps, phase shifters, or FACTS devices

2. Non-cost-free Methods

- Re-dispatch generation
- Curtail load/transaction



FACTS Device: TCSC

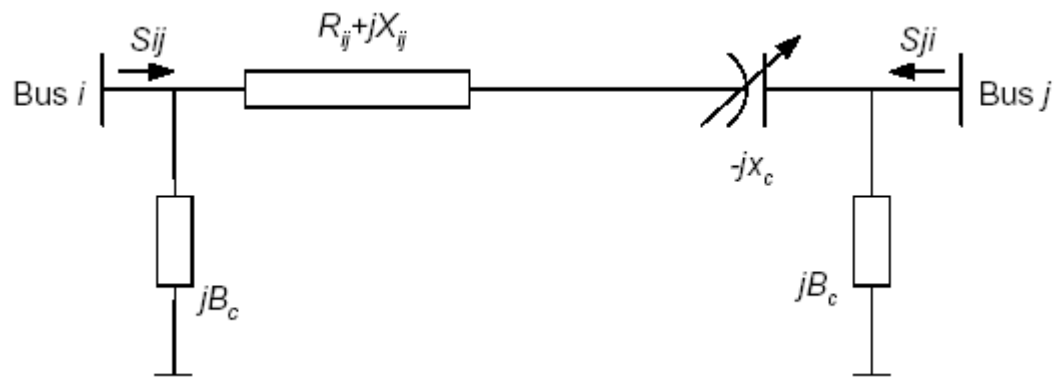

Model of TCSC (Thyristor-controlled series compensator)



FACTS Device: TCPAR and SVC

Thyristor-controlled phase angle regulator (TCPAR)

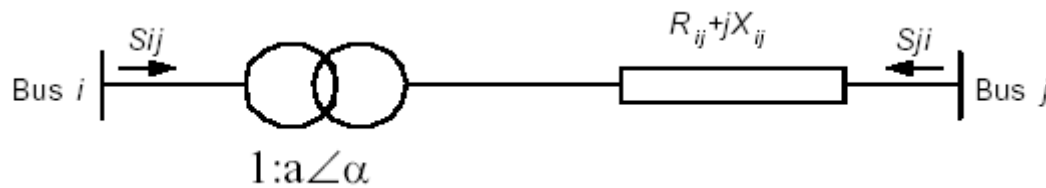

Static VAR compensator (SVC)

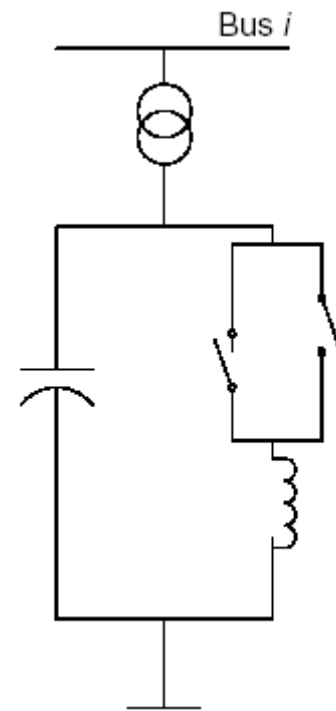



Thank you!

